



TECHNICAL GUIDE
ARMOUR PLATE FABRICATION



INTRODUCING OUR NEW PRODUCT NOMENCLATURE

Bisalloy Steels has recently introduced a new product nomenclature. The following table details the grade equivalents.

Note: Only the designation has changed – not the product

| Previous Name | New Name |
|-------------------------|---|
| BISPLATE® 60 | BISALLOY® Structural 60 steel |
| BISPLATE® 70 | BISALLOY® Structural 70 steel |
| BISPLATE® 80 | BISALLOY® Structural 80 steel |
| BISPLATE® 100 | BISALLOY® Structural 100 steel |
| BISPLATE® 80PV | BISALLOY® Structural 80 Pressure Vessel steel |
| BISPLATE® 320 | BISALLOY® Wear 320 steel |
| BISPLATE® 400 | BISALLOY® Wear 400 steel |
| BISPLATE® 450 | BISALLOY® Wear 450 steel |
| BISPLATE® 500 | BISALLOY® Wear 500 steel |
| BISPLATE® 600 | BISALLOY® Wear 600 steel |
| BISPLATE® HIA - Class 2 | BISALLOY® Armour RHA300 steel |
| BISPLATE® HIA - Class 1 | BISALLOY® Armour RHA360 steel |
| BISPLATE® HTA | BISALLOY® Armour HTA400 steel |
| BISPLATE® UHT | BISALLOY® Armour UHT440 steel |
| BISPLATE® HHA | BISALLOY® Armour HHA500 steel |
| BISPLATE® UHH | BISALLOY® Armour UHH600 steel |



BISALLOY® ARMOUR WELDING RECOMMENDATIONS

GENERAL INFORMATION

All grades of BISALLOY® Armour steel can be readily welded using conventional low hydrogen MMAW and GMAW welding consumables and processes. Chemical compositions are balanced with low carbon and alloy contents that ensure the armour not only has superior ballistic and mechanical properties but good weldability as well. All BISALLOY® Armour steel grades can be readily welded to other weldable steels. Carbon equivalents for all BISALLOY® Armour grades are listed in Table 1 below.

Table 1: Carbon equivalent for BISALLOY® Armour steel grades

| BISALLOY® ARMOUR STEEL GRADE | Plate Thickness (mm) | Carbon Equivalent (IIW) ¹ Typical | Pcm% (JWES) ² Typical |
|-------------------------------|----------------------|--|----------------------------------|
| BISALLOY® Armour RHA300 steel | 5 – 50 | 0.61 | 0.39 |
| BISALLOY® Armour RHA360 steel | 5 – 50 | 0.61 | 0.39 |
| BISALLOY® Armour HTA400 steel | 5 – 50 | 0.61 | 0.39 |
| BISALLOY® Armour UHT440 steel | 6 – 50 | 0.58 | 0.33 |
| BISALLOY® Armour HHA500 steel | 5 – 50 | 0.61 | 0.39 |
| BISALLOY® Armour VHH550 steel | 5.5 – 50 | 0.68 | 0.46 |
| BISALLOY® Armour UHH600 steel | 5.5 – 16 | 0.75 | 0.51 |

1) Carbon equivalent (CEQ, IIW) = C + Mn/6 + (Cr + Mo + V)/5 + (Ni + Cu)/15

2) Pcm% (JWES) = C + Si/30 + (Mn + Cu + Cr)/20 + Ni/ 60 + Mo/15 + V/10 + 5B

HYDROGEN CONTROL

To ensure adequate welding of BISALLOY® Armour steel plates, it is necessary to be more mindful of the levels of hydrogen introduced during welding to minimise the risk of weld and HAZ cold cracking. Weld hydrogen contents can be minimised with careful attention to the cleanliness and dryness of cold joint preparations and the use of hydrogen controlled welding consumables. Please consult consumable manufacturers for further guidance in the correct care and handling of low hydrogen consumables.

COOLING RATE

The properties of the HAZ are determined by the steel composition as well as the cooling rate. Too slow a cooling rate can result in a soft HAZ and thus a loss of tensile and fracture toughness properties. Too rapid a cooling rate produces a hard HAZ which may cause loss of ductility. Cooling is controlled by a balance between preheat and heat input for a particular plate thickness and joint configuration.

WORKING TEMPERATURE AND HEAT INPUT

Limitations on both preheat and heat input are necessary to ensure that the HAZ cools at an appropriate rate and that the correct hardness and microstructure are achieved. Preheating is necessary and the plate should be welded at a working temperature 25 – 200°C, dependent on plate grade, thickness and restraint conditions. The temperature should be maintained throughout the entire weld operation, in particular tack welding and root passes. The preheat/heat input recommendations are outlined in Table 2. Do not preheat plates above 200°C.

Joint Combined Thickness (mm) = $t_1 + t_2 + t_3$

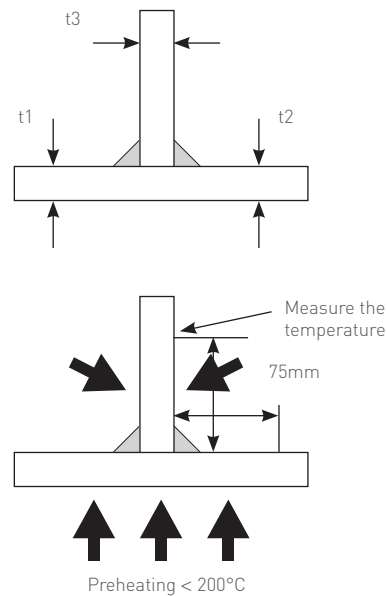

Table 2: Preheat/heat input recommendations for BISALLOY® Armour steel grades

| BISALLOY® ARMOUR STEEL GRADE | Joint Combined Thickness (mm) $t_1 + t_2 + t_3$ | | | |
|--|---|---------|----------|------|
| | <26 | ≥26 <50 | ≥50 <100 | ≥100 |
| BISALLOY® Armour RHA300/360 and HTA400 steel | 75 | 100 | 125 | 150 |
| BISALLOY® Armour UHT440 steel | - | 75 | 100 | 125 |
| BISALLOY® Armour HHA500 steel | 75 | 100 | 125 | 150 |
| BISALLOY® Armour VHH550 steel | 100 | 125 | 150 | 150 |
| BISALLOY® Armour UHH600 steel | 100 | 125 | 150 | 150 |
| MAX. INTERPASS TEMP (°C), ALL GRADES | 150 | 175 | 200 | 200 |
| MAX HEAT INPUT* (KJ/MM) MMAW, GMAW | 2.5 | 3.5 | 3.5 | 3.5 |

*Heat input (kJ/mm) = Volts x Amps x 0.06 / Travel Speed (mm/minute)

TACK WELDING

Tack welds require special care due to the abnormal stresses and high cooling rates experienced by the adjacent material. The same preheat/heat input requirements should be employed for final welding and lower strength welding consumables considered. When welding under high restraint conditions consideration should be given to the use of longer tack welds (>50mm) and lower strength consumables with high ductility.

WELDING PRACTICE

Good fillet welding techniques are important in welding BISALLOY® Armour steel plates because often very high stresses are applied in service. It is essential that welds have good root penetration, be smooth, correctly contoured and well flared into the legs of the joined pieces.

A good fit between the work pieces is essential to minimise stresses and thereby the risk of cracking.

All contaminants on and near weld joints such as mill scale, oil, paint and moisture should be removed before welding.

SELECTION OF CONSUMABLES

When selecting consumables consideration should be given to maximum allowable strength and toughness and levels of restraint encountered within the weldment. To obtain optimum weld joint properties of adequate design strength and good toughness it is necessary to select a consumable with the lowest strength allowable and high inherent toughness. Weld joints located in low stress areas should be carefully considered by designers.

Lower strength consumables are under matching for BISALLOY® Armour steel grades and offer better ductility

and toughness and reduce the susceptibility to cracking in the weld joints. The recommended consumables are listed in Table 3 below.

Table 3: Recommended AS and AWS classified consumables for welding of armour plate

| WELDING PROCESS | STRENGTH LEVEL | AS CLASSIFICATION | AWS CLASSIFICATION |
|-----------------|----------------|-----------------------|-------------------------------|
| MMAW | Lower | EG9XX,E55XX, E49XX | E110XX, E80XX, E70XX |
| GMAW | Lower | G69XX,G55XX, G49XX | ER110S-X, ER80S-X, ER70S-X |

Note:

1. Consumables listed in Table 3 are ferritic. Austenitic consumables may be used under high restraint welding conditions that require higher levels of ductility and toughness in the weldment or when the structure is subject to high levels of fatigue loading (such as in armoured vehicle). E308Mo or 307/19.9.6Mn have been successfully used to fabricate armoured vehicles. E308L and E309L are also acceptable for certain applications.
2. Table 3 only shows the classification of consumable.
3. End users/fabricators should consult consumable manufacturers to choose the most suitable ferritic or austenitic consumable for their application.



Picture supplied courtesy of the Lincoln Electric Company



BISALLOY® ARMOUR GRADE CUTTING RECOMMENDATIONS

GENERAL INFORMATION

All grades of BISALLOY® Armour steel can be readily cut using conventional cutting processes. The preferred methods are abrasive water jet cutting and/or laser cutting.

ABRASIVE WATER JET CUTTING

Abrasive water jet cutting can be applied to all BISALLOY® Armour steel plates and is the preferred method because the absence of HAZ eliminates the risk of cracking, particularly for BISALLOY® Armour VHH550 steel and UHH600 steel.

LASER CUTTING

Laser cutting generates low kerf, usually less than 1 mm and a narrow HAZ, usually less than 3 mm. As a result, laser cutting is the most popular cutting method for BISALLOY® Armour steel grades for thicknesses up to 20 mm. It is recommended to preheat BISALLOY® Armour UHH600 before laser cutting (see table below)

PLASMA CUTTING

BISALLOY® Armour steel grades up to around 40 mm thick can be cut using this process, creating kerf of about 3-4mm, and HAZ of about 5mm. It is recommended to preheat BISALLOY® Armour UHH600 steel before plasma cutting. (see Table 4 below).

Table 4: Recommended Preheat for Plasma Cutting/Laser Cutting

| BISALLOY® ARMOUR GRADE | PLATE THICKNESS (mm) | MIN PREHEATING TEMPERATURE (°C) |
|-------------------------------|----------------------|---------------------------------|
| BISALLOY® Armour UHH600 steel | ≤12 | 50 |
| | ≤16 | 75 |

FLAME CUTTING

Flame cutting can be applied to BISALLOY® Armour steel plates up to 50 mm and creates a kerf of 2-6mm and HAZ which is usually around 4-10 mm wide.

Uncontrolled flame cutting of BISALLOY® Armour HHA500, VHH550 and UHH600 steel may result in hydrogen cold cracking. The thicker the plate, the higher the sensitivity to cracking. The most effective way to minimize cracking during and after cutting is to preheat the plate and keep the cut parts at an elevated temperature. (see Table 5 below).

Table 5: Recommended Preheat for Flame Cutting

| BISALLOY® ARMOUR GRADE | PLATE THICKNESS (mm) | MIN PREHEATING TEMPERATURE (°C) |
|---------------------------------------|----------------------|---------------------------------|
| BISALLOY® Armour RHA300, RHA360 steel | 32- 50 | 50 |
| BISALLOY® Armour HTA400, UHT440 steel | >20 – 50 | 50 |
| BISALLOY® Armour HHA500 steel | 6 - 20 | 50 |
| | >20 – 50 | 75 |
| BISALLOY® Armour VHH550 steel | 6 - 20 | 50 |
| | >20 – 50 | 75 |
| BISALLOY® Armour UHH600 steel | ≤12 | 50 |
| | ≤16 | 75 |

DISTORTION AFTER CUTTING

BISALLOY® Armour HHA500, VHH550 and UHH600 have very high hardnesses and may contain high residual stresses. It is recommended that the following practices be used to minimise distorting after cutting:

- Avoid using excessive cutting speeds as this can be detrimental. Laser profilers generally use the highest cutting speed while maintaining good finish for efficiency and productivity. High speed cutting with good surface finish is generally acceptable for lower hardness grades of BISALLOY® Armour but may not necessarily be the correct parameter for cutting BISALLOY® high hardness armour grades such as UHH600, VHH550 and HHA500. Very high laser cutting speed generally increases distortion after cutting and probability of edge cracking. For example, when laser cutting 7mm BISALLOY® Armour UHH600, it is recommended to use travel speed of 1000-1200mm/min at nominal power of 2kW (machine used LVD Impuls 12530 with a max capacity of 6kW)
- Use a stitch cutting technique, leaving small tabs along the cutting line to restrain the component from moving due to distortion.
- Use a cutting sequence which minimises heat concentration.

Should springback occur after laser cutting/profiling into small parts, pressing/leveling either using bend press or roller leveller can be used. Such practices will not affect mechanical properties and ballistic performance.

Preheat according to Table 4 can be used when pressing/levelling parts however do not exceed 200°C.

When the part needs to be pressed/levelled, use recommended bending procedures (see page No.8).



BISALLOY® ARMOUR BENDING RECOMMENDATIONS

BENDING

All BISALLOY® Armour steel grades can be cold bent by the brake press-bending method as shown in Figure 1. Plate rolling techniques can also be employed. However, BISALLOY® Armour steel grades have higher hardness and strength levels compared to plain carbon steels and therefore suitable consideration of sufficient machine power, plate bending direction and former radii (R) must be made. BISALLOY® Armour steel plates should be bent at room temperature to avoid reduction of mechanical and ballistic properties.

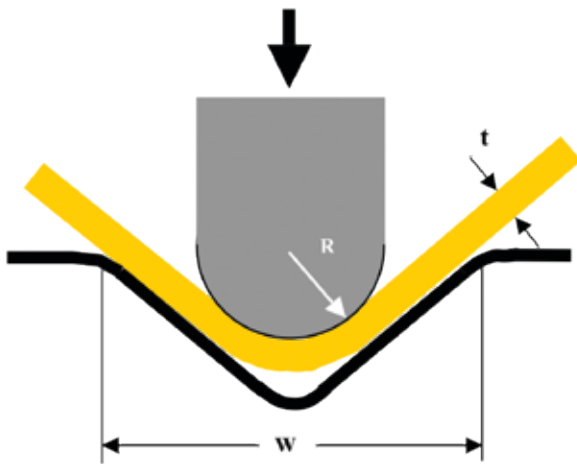

Figure 1. Schematic diagram of bending.

BISALLOY® Armour steel plate, like all hot rolled plate, displays slightly different mechanical properties in the direction of rolling compared to the transverse direction. It is recommended that where possible the bend axis be at right angles to the plate rolling direction (transverse bending) as shown in Figure 2.

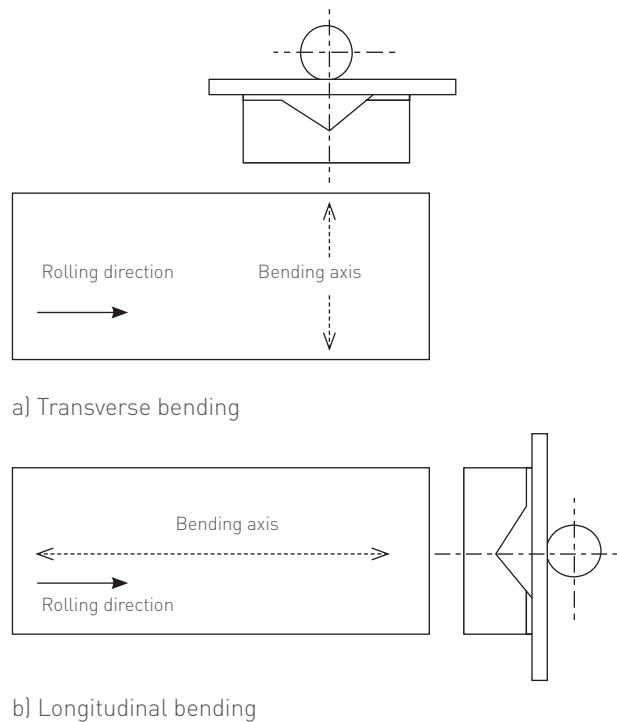

Figure 2. Schematic diagrams of transverse and longitudinal bend directions.

Plates can be bent in longitudinal direction but need larger radius former as shown in Table 6.

FORMER

The minimum former radius (R) related to plate thickness (t) for all BISALLOY® Armour steel grades are listed in Table 6.

Table 6: Minimum former radius for bending of armour grades

| BISALLOY® ARMOUR STEEL GRADE | Bending Former Radius R/Plate Thickness t (R/t) | | | | | | | | | |
|------------------------------|---|-------|--------|-------|--------|-------|--|-------|--------|-------|
| | RHA300, RHA360, HTA400 | | UHT440 | | HHA500 | | VHH550 | | UHH600 | |
| PLATE THICKNESS (mm) | Trans. | Long. | Trans. | Long. | Trans. | Long. | Trans. | Long. | Trans. | Long. |
| 5 | 2.5 | 3.0 | 3.0 | 3.5 | 4.0 | 4.5 | 6.0 | 9.0 | 7.0 | 10.0 |
| 6 | 3.0 | 3.5 | 3.5 | 4.0 | 4.0 | 4.5 | 6.0 | 9.0 | 7.0 | 10.0 |
| 8 | 3.0 | 4.0 | 3.5 | 4.5 | 4.5 | 5.0 | 6.0 | 9.0 | 7.0 | 10.0 |
| 10 | 3.0 | 4.0 | 4.0 | 5.0 | 4.5 | 5.5 | 6.0 | 9.0 | 7.0 | 10.0 |
| 12 | 3.0 | 4.0 | 4.0 | 5.0 | 4.5 | 5.5 | 6.0 | 9.0 | 7.0 | 10.0 |
| 16 | 3.5 | 4.5 | 4.5 | 5.5 | 5.0 | 6.0 | 6.0 | 9.0 | 7.0 | 10.0 |
| 20 | 4.0 | 5.0 | 4.5 | 5.5 | 5.5 | 6.5 | Contact Bisalloy Technical Managers if bending is required | | | |
| 25 | 4.5 | 5.5 | 5.0 | 6.0 | 5.5 | 6.5 | | | | |
| 32 | 4.5 | 5.5 | 5.0 | 6.0 | 6.0 | 7.0 | | | | |
| 40 | 4.5 | 5.5 | 5.0 | 6.0 | - | - | | | | |
| 50 | 4.5 | 5.5 | 5.0 | 6.0 | - | - | | | | |

Note Table 6

1. Bending should be conducted at room temperature. All BISALLOY® Armour steel plates should not be bent at temperatures above 200°C. Bending BISALLOY® Armour steel plate at low temperatures (<10°C), requires an increase in former radii of 50% minimum.

2. When bending using these minimum former radii, the flame cut hardened edge (heat affected zone 1-2mm) should be removed before bending and welded components are not recommended to be bent using the values in the table. Cut and sheared edges should be ground and rounded with grinder.

3. For best bending results ensure adequate lubrication between the plate, die and former. Proper lubrication can reduce bending forces by 10 to 25%

DIE

The die edges must be clean and undamaged. The bending force and the risk of cracking can be reduced by using round edge die and by lubricating the die edges. The relationship between die open (W) and plate thickness (t) for bending all BISALLOY® Armour steel plates is listed in Table 7.

Table 7: Die open (W) / thickness (t) for bending armour plates

| BISALLOY® ARMOUR GRADE | TRANSVERSE BEND (W/t) | LONGITUDINAL BEND (W/t) |
|---|-----------------------|-------------------------|
| BISALLOY® Armour RHA300, RHA360, HTA400 steel | 12 | 16 |
| BISALLOY® Armour UHT440 steel | 13 | 17 |
| BISALLOY® Armour HHA500 steel | 14 | 18 |
| BISALLOY® Armour VHH550 steel | 17 | 19 |
| BISALLOY® Armour UHH600 steel | 18 | 20 |

SPRING BACK

Spring back after bending is expected due to the high hardness of BISALLOY® Armour steel plates. It has been estimated that about 10 to 15° spring back can be expected for BISALLOY® Armour RHA300, RHA360, HTA400 and UHT440 steel and 15 to 20° for Bisalloy® Armour HHA500 steel.

BISALLOY® ARMOUR DRILLING, COUNTERSINKING AND TAPPING RECOMMENDATIONS

All grades of BISALLOY® Armour steel are able to be drilled, countersunk and tapped although, as with most fabrication aspects, care should be taken with these grades of steel.

In all cases, suitable high powered and rigid drilling equipment should be used.

DRILLING OF BISALLOY® ARMOUR STEEL GRADES

BISALLOY® Armour steel grades (RHA300, RHA360, HTA400, UHT440) may be drilled with either cobalt type high speed steel drills or drills equipped with replaceable carbide inserts.

With regards to the drilling of BISALLOY® Armour HHA500/ VHH550/UHH600 steel, we recommend only the use of drills equipped with replaceable carbide inserts.

Recommendations for improved results

- The supporting bars under the plate should be placed as close to the hole as possible.
- If possible, use a plain carbon steel backing plate under the BISALLOY® steel.
- The drilling head should be placed as close as possible to the main support.
- Short length drills are preferred.
- The last part of the hole to be drilled should be done with manual feed.
- Usage of adequate coolant (water and oil emulsion mixture).

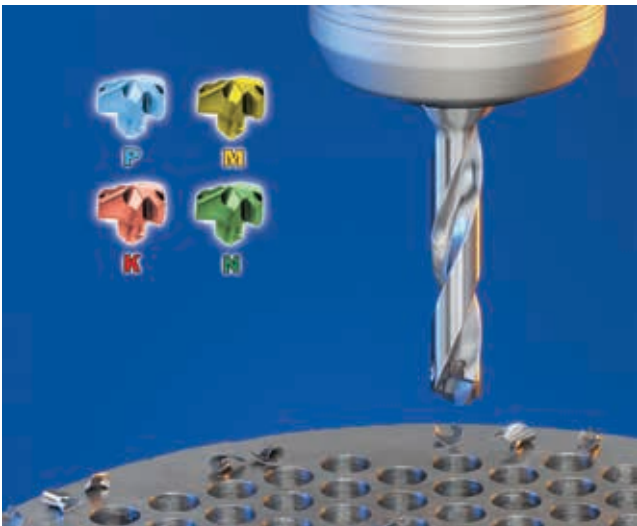

APPROXIMATE FEEDS AND SPEEDS USING COBALT TYPE HIGH SPEED STEEL DRILLS

Table 8:

| BISALLOY® ARMOUR STEEL GRADE | PERIPHERAL SPEED (m/min) | R.P.M (UPPER FIGURES) AND FEED PER REVOLUTION (mm) FOR GIVEN DRILL SIZE | | | | | | HARDNESS BRINELL |
|--|--------------------------|---|------|------|------|------|------|------------------|
| | | 5 | 10 | 15 | 20 | 25 | 30 | |
| AS3678-Grade 250 (Mild Steel) | 23 | 1465 | 735 | 490 | 370 | 295 | 245 | ~120 |
| | | 0.10 | 0.15 | 0.20 | 0.25 | 0.35 | 0.4 | |
| BISALLOY® Armour RHA300 / RHA360 steel | 12 | 760 | 380 | 250 | 190 | 150 | 130 | 320 (min) |
| | | 0.07 | 0.10 | 0.16 | 0.23 | 0.30 | 0.35 | |
| BISALLOY® Armour HTA400 steel | 9 | 570 | 285 | 190 | 150 | 110 | 90 | 370 (min) |
| | | 0.05 | 0.10 | 0.16 | 0.23 | 0.30 | 0.35 | |
| BISALLOY® Armour UHT440 steel | 7 | 440 | 220 | 150 | 110 | 90 | 75 | 420 (min) |
| | | 0.05 | 0.09 | 0.15 | 0.20 | 0.25 | 0.30 | |

DRILL TIP CONFIGURATION USING COBALT TYPE HIGH SPEED STEEL DRILLS

Note: This table applies when cobalt type high speed drills are used with a cutting fluid, if no fluid is used the speeds shown above must be reduced.

Table 9:

| BISALLOY® ARMOUR STEEL GRADE | POINT ANGLE | LIP/CLEARANCE ANGLE |
|--|-------------|---------------------|
| BISALLOY® Armour RHA300 / RHA360 steel | 125 deg. | 7.5 deg. |
| BISALLOY® Armour HTA400 / UHT440 steel | 150 deg. | 5 deg. |

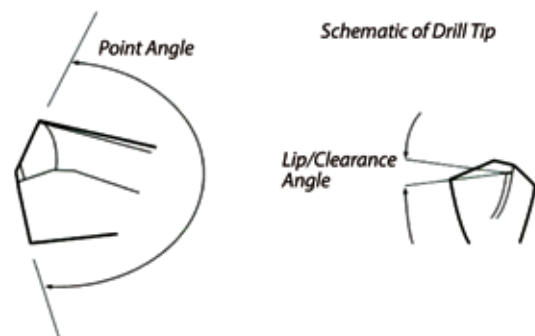

Recommended Drill Tip Configuration for Cobalt Type High Speed Drills

APPROXIMATE FEEDS AND SPEEDS USING DRILLS WITH REPLACEABLE CARBIDE INSERTS

Table 10:

| BISALLOY® ARMOUR STEEL GRADE | ISCAR INSERT GRADE | SURFACE SPEED (m/min) | FEED RATE (mm/rev) | HARDNESS BRINELL |
|--|--------------------|-----------------------|--------------------|------------------|
| BISALLOY® Armour RHA300 / RHA360 steel | IC908 or IC808 | 120 - 180 | 0.08 - 0.20 | 260 - 400 |
| BISALLOY® Armour HTA400 steel | IC908 or IC808 | 100 - 160 | 0.06 - 0.18 | 370 - 430 |
| BISALLOY® Armour UHT440 steel | IC908 or IC808 | 80 - 100 | 0.06 - 0.18 | 420 - 470 |
| BISALLOY® Armour HHA500 steel | IC908 or IC808 | 70 - 90 | 0.06 - 0.14 | 500 (typical) |
| BISALLOY® Armour VHH550 steel | IC908 or IC808 | 60 - 80 | 0.06 - 0.13 | 550 (typical) |
| BISALLOY® Armour UHH600 steel | IC908 or IC808 | 50 - 70 | 0.06 - 0.12 | 600 (typical) |



Note: Above drilling recommendations are based on using a ISCAR "DR DRILL" and is based on hole sizes of 12.0 - 70.0 mm diameter. Through the tool coolant must be used. Feed rates are governed by the insert size related to the diameter of the drill.

Further information can be obtained from your local ISCAR representative or ISCAR head office Sydney.

ISCAR Australia Pty Ltd. Toll free phone: 1800 806 016 or email: iscaraus@iscar.com.au

COUNTERSINKING AND COUNTERBORING

Table 11:

| BISALLOY® STEEL GRADE | CUTTING SPEED (m/ min) | Ø16 | | Ø20 | | Ø25 | | Ø32 | | Ø40 | | Ø60 | |
|---|------------------------------|--------------|----------------|--------------|----------------|-------------|----------------|-------------|----------------|-------------|----------------|-------------|----------------|
| | | RPM | FEED (mm/r) | RPM | FEED (mm/r) | RPM | FEED (mm/r) | RPM | FEED (mm/r) | RPM | FEED (mm/r) | RPM | FEED (mm/r) |
| BISALLOY® Armour RHA300 / RHA360 steel | 25-70 | 450- 1200 | 0.10 -0.20 | 420- 1175 | 0.10 -0.20 | 330- 930 | 0.10 -0.20 | 235- 660 | 0.10 -0.20 | 190- 530 | 0.10 -0.20 | 130- 390 | 0.10 -0.20 |
| BISALLOY® Armour HTA400 / UHT440 steel | 20-50 | 350- 880 | 0.10 -0.20 | 330- 840 | 0.10 -0.20 | 260- 660 | 0.10 -0.20 | 190- 470 | 0.10 -0.20 | 160- 380 | 0.10 -0.20 | 105- 280 | 0.10 -0.20 |
| BISALLOY® Armour HHA500 steel | 17-45 | 300- 860 | 0.10 -0.20 | 280- 820 | 0.10 -0.20 | 220- 660 | 0.10 -0.20 | 160- 470 | 0.10 -0.20 | 130- 370 | 0.10 -0.20 | 90- 270 | 0.10 -0.20 |
| BISALLOY® Armour VHH550 steel | 14-40 | 260- 780 | 0.10 -0.20 | 240- 740 | 0.10 -0.20 | 180- 590 | 0.10 -0.20 | 135- 420 | 0.10 -0.20 | 110- 330 | 0.10 -0.20 | 80- 240 | 0.10 -0.20 |
| BISALLOY® Armour UHH600 steel | 12-40 | 220- 700 | 0.10 -0.20 | 200- 670 | 0.10 -0.20 | 150- 530 | 0.10 -0.20 | 110- 370 | 0.10 -0.20 | 90- 300 | 0.10 -0.20 | 65- 220 | 0.10 -0.20 |

Countersinking and counterboring of holes is possible in all BISALLOY® Armour steel grades with best performance obtained using tools with a revolving pilot. The pilot increases the stability and allows tools with replaceable carbide inserts to be used. Countersinking / boring are best performed using tools which have replaceable inserts.



Bisalloy Steels wish to thank Sandvik Coromant and Ti-Tek for the information pertaining to drilling, tapping and countersinking contained in this publication.

TAPPING SPEEDS AND TYPES RECOMMENDED FOR BISALLOY® ARMOUR STEEL GRADES

Table 12:

| BISALLOY® STEEL GRADE | TAP TYPE (prototype) | TAPPING SPEED (m/min) | SIZE RANGE | LUBRICATION |
|--|----------------------|-----------------------|------------|-------------|
| BISALLOY® Armour RHA300 / RHA360 steel | Prototex Inox 202135 | 6 – 15* | M1.6 – M36 | Cutting Oil |
| BISALLOY® Armour HTA400 steel | Prototex Inox 202135 | 6 – 15* | M1.6 – M36 | Cutting Oil |
| BISALLOY® Armour UHT440 steel | Prototex Ni 202602 | 3 | M1.6 – M24 | Cutting Oil |
| BISALLOY® Armour HHA500 steel | Paradur H/C 80311 | 1.6 | M3 – M12** | Cutting Oil |
| BISALLOY® Armour VHH550 steel / UHH600 steel | Paradur H/C 80311 | 1.2 | M3 – M12** | Cutting Oil |

*6m/min using steam tempered taps and 15m/min using tin coated tips.

**For larger size threads, thread milling is recommended.



TAPPING

With the correct tools and cutting speeds, tapping can be performed in all the BISALLOY® Armour steel grades of steel.

Difficulties that commonly arise when thread cutting higher tensile strength steels include tap sticking, torn threads and the short life of taps. The Prototyp brand tools have been specifically developed for tapping in the BISALLOY® Steels grades of steel.

With all tapping it is recommended that the cutting speed is accurately controlled.

For best results, cutting oil or grease should be used. For through-holes of up to 2 times diameter in thread depth, in metric sizes, the following tapping tools are recommended.

Note: The introduction of stress concentrations (as a result of tapping) is an important consideration in fatigue applications.

